

10RHB2

Inductance Range: 10~3900 μ H

DIMENSIONS / 外形寸法図

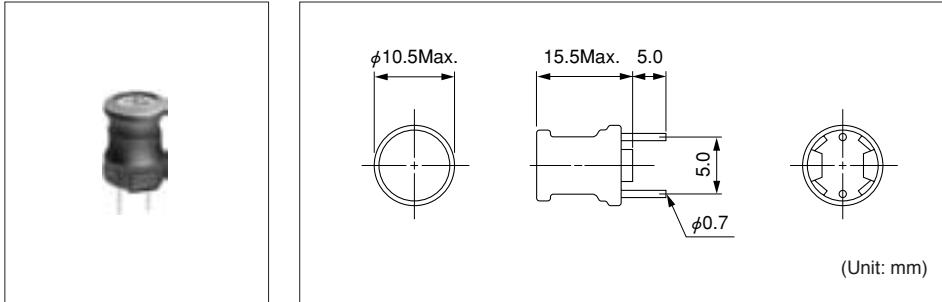

FEATURES / 特長

- Open magnetic circuit construction.
- High rated current.
- 5 mm-pitch, 2-terminals fixed inductor.
- Ideal for use as choke coil for high current circuits in all types of electronic instruments.
- RoHS compliant.
- 開磁路構造
- 定格電流が大きい
- 5mmピッチの2端子形固定インダクタ
- 各種電子機器の大電流回路チョークコイルに最適
- RoHS指令対応

SELECTION GUIDE FOR STANDARD COILS

TYPE 10RHB2 Covered with Heat Shrunk Cover 熱収縮チューブカバー付

東光品番	インダクタンス ⁽¹⁾	許容差	直流抵抗 ⁽⁴⁾	最大許容電流 ⁽²⁾	自己共振周波数 ⁽³⁾⁽⁵⁾
TOKO Part Number	Inductance ⁽¹⁾ L (μ H)	Tolerance (%)	DC Resistance ⁽⁴⁾ (Ω) Max.	Rated DC Current ⁽²⁾ (A) Max.	Self-resonant Frequency ⁽³⁾⁽⁵⁾ (MHz) Min.
#824LY-100K	10	± 10	0.052	2.20	44
#824LY-120K	12	± 10	0.059	2.00	33
#824LY-150K	15	± 10	0.065	1.93	25
#824LY-180K	18	± 10	0.071	1.77	16
#824LY-220K	22	± 10	0.076	1.72	12
#824LY-270K	27	± 10	0.082	1.56	8.3
#824LY-330K	33	± 10	0.086	1.49	5.9
#824LY-390K	39	± 10	0.095	1.40	4.9
#824LY-470K	47	± 10	0.11	1.29	4.1
#824LY-560K	56	± 10	0.12	1.25	4.0
#824LY-680K	68	± 10	0.13	1.24	3.9
#824LY-820K	82	± 10	0.14	1.04	3.6
#824LY-101K	100	± 10	0.18	1.02	2.8
#824LY-121K	120	± 10	0.19	0.94	2.6
#824LY-151K	150	± 10	0.22	0.92	2.2
#824LY-181K	180	± 10	0.25	0.85	2.1
#824LY-221K	220	± 10	0.28	0.82	1.9
#824LY-271K	270	± 10	0.46	0.60	1.6
#824LY-331K	330	± 10	0.50	0.56	1.5
#824LY-391K	390	± 10	0.56	0.52	1.4
#824LY-471K	470	± 10	0.62	0.48	1.3
#824LY-561K	560	± 10	0.69	0.45	1.2
#824LY-681K	680	± 10	0.79	0.44	1.1
#824LY-821K	820	± 10	0.86	0.40	1.0
#824LY-102K	1000	± 10	1.60	0.31	0.87

continued from previous page
前頁より続く

TYPE 10RHB2 Covered with Heat Shrunken Cover 熱収縮チューブカバー付

東光品番	インダクタンス ⁽¹⁾	許容差	直流抵抗 ⁽⁴⁾	最大許容電流 ⁽²⁾	自己共振周波数 ⁽³⁾⁽⁵⁾
TOKO Part Number	Inductance ⁽¹⁾ L (μH)	Tolerance (%)	DC Resistance ⁽⁴⁾ (Ω) Max.	Rated DC Current ⁽²⁾ (A) Max.	Self-resonant Frequency ⁽³⁾⁽⁵⁾ (MHz) Min.
#824LY-122K	1200	± 10	1.80	0.28	0.83
#824LY-152K	1500	± 10	2.10	0.27	0.77
#824LY-182K	1800	± 10	2.30	0.24	0.71
#824LY-222K	2200	± 10	2.60	0.24	0.66
#824LY-272K	2700	± 10	3.35	0.19	0.61
#824LY-332K	3300	± 10	4.00	0.18	0.52
#824LY-392K	3900	± 10	4.50	0.16	0.48

TYPE 10RHB2 without Cover カバー無し

東光品番	インダクタンス ⁽¹⁾	許容差	直流抵抗 ⁽⁴⁾	最大許容電流 ⁽²⁾	自己共振周波数 ⁽³⁾⁽⁵⁾
TOKO Part Number	Inductance ⁽¹⁾ L (μH)	Tolerance (%)	DC Resistance ⁽⁴⁾ (Ω) Max.	Rated DC Current ⁽²⁾ (A) Max.	Self-resonant Frequency ⁽³⁾⁽⁵⁾ (MHz) Min.
#824LYF-100K	10	± 10	0.052	2.20	44
#824LYF-120K	12	± 10	0.059	2.00	33
#824LYF-150K	15	± 10	0.065	1.93	25
#824LYF-180K	18	± 10	0.071	1.77	16
#824LYF-220K	22	± 10	0.076	1.72	12
#824LYF-270K	27	± 10	0.082	1.56	8.3
#824LYF-330K	33	± 10	0.086	1.49	5.9
#824LYF-390K	39	± 10	0.095	1.40	4.9
#824LYF-470K	47	± 10	0.11	1.29	4.1
#824LYF-560K	56	± 10	0.12	1.25	4.0
#824LYF-680K	68	± 10	0.13	1.24	3.9
#824LYF-820K	82	± 10	0.14	1.04	3.6
#824LYF-101K	100	± 10	0.18	1.02	2.8
#824LYF-121K	120	± 10	0.19	0.94	2.6
#824LYF-151K	150	± 10	0.22	0.92	2.2
#824LYF-181K	180	± 10	0.25	0.85	2.1
#824LYF-221K	220	± 10	0.28	0.82	1.9
#824LYF-271K	270	± 10	0.46	0.60	1.6
#824LYF-331K	330	± 10	0.50	0.56	1.5
#824LYF-391K	390	± 10	0.56	0.52	1.4
#824LYF-471K	470	± 10	0.62	0.48	1.3
#824LYF-561K	560	± 10	0.69	0.45	1.2
#824LYF-681K	680	± 10	0.79	0.44	1.1
#824LYF-821K	820	± 10	0.86	0.40	1.0
#824LYF-102K	1000	± 10	1.60	0.31	0.87
#824LYF-122K	1200	± 10	1.80	0.28	0.83
#824LYF-152K	1500	± 10	2.10	0.27	0.77
#824LYF-182K	1800	± 10	2.30	0.24	0.71
#824LYF-222K	2200	± 10	2.60	0.24	0.66
#824LYF-272K	2700	± 10	3.35	0.19	0.61
#824LYF-332K	3300	± 10	4.00	0.18	0.52
#824LYF-392K	3900	± 10	4.50	0.16	0.48

(1) Inductance is measured with a LCR meter 4284A(Agilent Technologies) or equivalent.

Test frequency at 1.0kHz

(2) Maximum allowable DC current is that which causes a 10% inductance reduction from the initial value, or coil temperature to rise by 20°C, whichever is smaller. (Reference ambient temperature 20°C)

(3) Self-resonant frequency is measured with a network analyzer model MS560J (Anritsu) or equivalent.

(4) DC resistance is measured with a digital multimeter TR6871(Advantest) or equivalent.

(5) Self-resonant frequency is for reference only.

(1) インダクタンスはLCRメータ4284A(Agilent Technologies)または同等品で測定する。測定周波数は1.0kHzです。

(2) 最大許容電流は、直流電流を流した時インダクタンスの値が初期値より10%減少する直流電流値、または直流電流により、コイルの温度が20℃上昇の何れか小さい値です。(周囲温度20℃を基準とする。)

但し()内の値は参考値として直流電流特性による電流値です。

(3) 自己共振周波数はネットワークアナライザMS560J (Anritsu)または同等品により測定する。

(4) 直流抵抗はデジタルマルチメータTR6871(Advantest)または同等品により測定する。

(5) 自己共振周波数は、参考値です。